



Model 型号

Page

1 / 20

GMB201030R-L 43mAh 3.7V

Ver.

1.0

PRODUCT SPECIFICATION

Advanced Rechargeable Polymer Lithium-ion Battery

聚合物锂离子电池产品规格书

| | |
|-----------------------|--------------|
| Battery Model 电池型号 | GMB201030R-L |
|-----------------------|--------------|

Customer Approval 客户确认

| | |
|---------------------------|--|
| Customer Name 客户名称 | |
| Signature/Date 客户签名/日期 | |
| Company Stamp 客户印章 | |

| | | |
|----------------|---------------|----------------|
| Prepared by 编制 | Checked by 审核 | Approved by 批准 |
| | | |



Model 型号

Page

2 / 20

GMB201030R-L 43mAh 3.7V

Ver.

1.0

History of Revision

修改履历表

| Rev.版本 | Description 变更描述 | Date 日期 |
|--------|------------------|-----------|
| 1.0 | First issue 首次发行 | 2013-5-10 |
| | | |
| | | |
| | | |
| | | |
| | | |
| | | |
| | | |
| | | |
| | | |
| | | |
| | | |
| | | |
| | | |
| | | |
| | | |



Model 型号

Page

3 / 20

GMB201030R-L 43mAh 3.7V

Ver.

1.0

Contents

目 录

| | |
|---|----|
| 1 Scope 范围 | 4 |
| 2 Description and Model 电芯类型与型号 | 4 |
| 3 Cell Technical Information..... | 5 |
| 4 Cell Electrical Characteristics 电性能 | 6 |
| 5 Battery Performance..... | 10 |
| 6 Print Code 喷码 | 14 |
| 7 Storage 贮存 | 15 |
| 8 Period of Warranty 保质期..... | 15 |
| 9 Shipment 运输..... | 15 |
| 10 Others 其他 | 15 |
| Appendix 附录..... | 16 |

1 Scope 范围

This specification is applied to Polymer Lithium-ion battery manufactured by Guangzhou Markyn Battery Co., Ltd.

本规格书适用于广州基安彼电池有限公司生产的聚合物锂离子电池。

2 Description and Model 电芯类型与型号

2.1 Cell Description 电芯类型: Polymer Lithium Ion Battery 聚合物锂离子电芯

2.2 Cell Model 电芯型号: GMB201030R-L

2.3 Cell Outer Dimension 电芯外形尺寸:

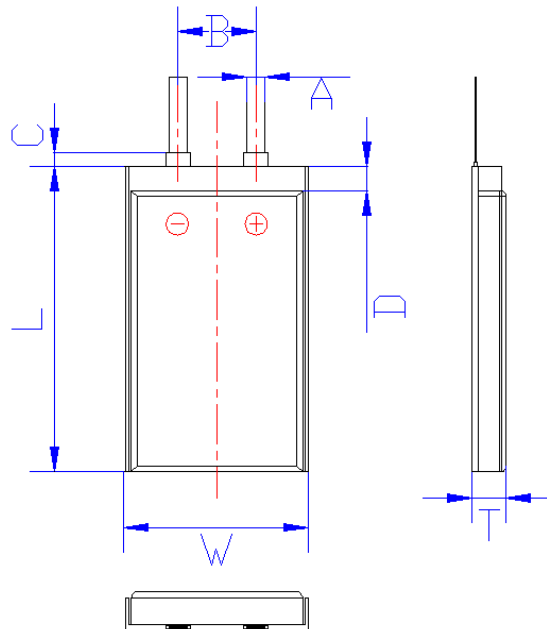

Unit: mm

| Item 项目 | Description 描述 | | Dimension 尺寸 |
|---------|-------------------------------|--------------------------|--------------|
| T | Cell thickness 厚度 | Initial 初始状态 | 2.0±0.2 |
| | | After 400 cycle 400 次循环后 | Max.2.3 |
| W | Cell width 宽度 | | 9.5±0.5 |
| L | Cell length 长度 | | 30.0±0.5 |
| A | Cell tab width 极耳宽度 | | 2.0±0.1 |
| B | Cell tab Pitch 极耳中心距 | | 5.0±0.5 |
| C | Cell tab glue 极耳胶外露尺寸 | | 0.5~2.0 |
| D | Cell top sealant length 顶封边宽度 | | 3.5±1.0 |

3 Cell Technical Information

| Item 项目 | Rating 额定参数 | Note 备注 |
|--|----------------------------------|--|
| 3.1 Typical Capacity 标称容量 | 43 mAh | 8.6mA(0.2C)discharge, 3.0V cutoff 8.6mA(0.2C)恒流放电至 3.0V |
| Minimum Capacity 最小容量 | 40 mAh | |
| 3.2 Nominal Voltage 标称电压 | 3.7 V | |
| 3.3 Standard Charge Current 标准充电电流 | 8.6 mA(0.2C) | Ambient temperature 环境温度: 0 ~ +40°C |
| 3.4 Maximum Charge Current 最大充电电流 | 43 mA(1.0C) | Ambient temperature 环境温度: 0 ~ +40°C |
| 3.5 Charging Voltage 充电截止电压 | 4.20±0.03 V | |
| 3.6 Charging time (Std. charge current) 标准充电时间 (标准充电电流) | 6.0~7.0 hours | |
| 3.7 Charging time (Max. charge current) 标准充电时间 (最大充电电流) | 2.0~3.0 hours | |
| 3.8 Standard Discharge Current 标准放电电流 | 8.6 mA(0.2C) | Ambient temperature 环境温度: 0 ~ +40°C |
| 3.9 Maximum Discharge Current 最大放电电流 | 86 mA(2.0C) | Ambient temperature 环境温度: 0 ~ +40°C |
| 3.10 Discharge Cut-off Voltage 放电截止电压 | 3.0 V | |
| 3.11 Cell Impedance 电芯内阻 | ≤350 mΩ | AC Impedance 交流内阻(1KHz) |
| 3.12 Cell Weight 电芯重量 | Approx. 1.1 g | |
| 3.13 Voltage as of shipment 运输电压 | 3.7~3.9 V | |
| 3.14 Operating Temperature 工作温度 | 0~45°C -20~60°C | Charge 充电 Discharge 放电 |
| 3.15 Storage Temperature 贮存温度 | -20~60°C -20~40°C -20~20°C | 1 month 1个月 3 month 3个月 1 year 1年 |

4 Cell Electrical Characteristics 电性能

4.1 Standard test condition 标准测试条件

4.1.1 Standard environmental test condition 测试标准环境

Test should be conducted with new batteries within one month after shipment from our factory and the cells shall not be cycled more than five times before the test. Test condition shall be at $23 \pm 2^\circ\text{C}$ and $65 \pm 20\% \text{RH}$. 测试电池必须是本公司出厂时间不超过一个月的新电池，且电池未进行过五次以上充放电循环。除非其它特殊要求，本产品规格书规定的测试条件为：温度 $23 \pm 2^\circ\text{C}$ ，相对湿度 $65 \pm 20\%$ 。

4.1.2 Measuring Instrument or Apparatus 测试仪器或设备

4.1.2.1 Dimension Measuring Instrument 尺寸测量仪器

The dimension measurement shall be implemented by instruments with equal or more precision scale of 0.01mm. 测量尺寸的仪器精度应大于或等于 0.01mm。

4.1.2.2 Voltmeter 万用表

Standard class specified in the national standard or more sensitive class having inner impedance more than 10 M Ω /V. 万用表测量电压及电流的准确度应不低于 0.5 级，测量电压时内阻不应小于 10k Ω /V。

4.1.2.3 Impedance Meter 内阻测试仪

Impedance shall be measured by a sinusoidal alternating current method (1kHz LCR meter). 内阻测试仪测量原理应为交流阻抗法(1kHz LCR)。

4.1.2.4 Battery Test System 电池测试系统

The precision of scale of test system is demanded as follow:

测试系统精度须满足下表要求：

| 项目名称 Item | 电压 Voltage | 电流 Current | 时间 Time |
|----------------|-------------|------------|-------------|
| 测量公差 tolerance | $\pm 0.2\%$ | $\pm 1\%$ | $\pm 0.1\%$ |

4.1.3 Standard Charge Definition 标准充电定义

Standard charge is defined by charging for 7.0 hours at 4.2V of constant voltage and 8.6mA (0.2C) of constant current, 1.3mA(0.03C) cutoff. 以 8.6mA (0.2C)恒流充电至 4.2V，转 4.2V 恒压充电，电流截止为 1.3mA(0.03C)，总充电时间不超过 7.0 小时。

4.1.4 Rest Period 搁置时间

Unless otherwise defined, 10min rest period after full charge, 10min rest period after discharge. 如无其它特殊要求，充放电过程之间的时间间隔为 10min。

4.1.5 Standard Discharge Definition 标准放电定义

Standard Discharge is defined by discharging at 8.6 mA (0.2C) down to 3.0V. 8.6mA(0.2C)电流恒流放电至 3.0V。

4.2 Electrical Performance 电化学性能

| No. 序号 | Item 项目 | Test Condition 测试方法 | Criterion 标准 |
|--------|---|--|--|
| 1 | Open-Circuit Voltage 开路电压 | The open-circuit voltage shall be measured within 24 hours after standard charge. 标准充电后，24 小时内测量电池的开路电压。 | $\geq 4.15V$ |
| 2 | Internal Resistance 内阻(光身电芯) | The Impedance shall be measured in an alternating current method after standard charge. 标准充电后，采用交流法测量电池内阻。 | $\leq 350m\Omega$ |
| 3 | Initial Capacity(C_{ini}) 初始放电容量 | Standard charge, and standard discharge. 标准充电后，标准放电测试电池容量。 | $\geq 43mAh$ |
| 4 | High Rate Discharge Capacity 高倍率放电容量 | Standard charge, and discharge at 86mA(2.0C) down to 3.0V cutoff. 标准充电后，以 86mA (2.0C) 放电至 3.0V 测试电池容量。 | $\geq 34.4mAh$ |
| 5 | Temperature Characteristics 放电温度特性 | Charge: standard charge. Rest: ≥ 8 hours at required temperature. Discharge: CC, 8.6mA(0.2C), 3.0V cutoff. 标准充电后，在要求的温度下搁置 8 小时以上，然后以 8.6mA(0.2C)放电至 3.0V。 | 60°C: $\geq 40.8mAh$ 0°C: $\geq 38.7mAh$ -20°C: $\geq 30.1mAh$ |
| 6 | Cycle Life 循环寿命 | Charge: CC-CV, 43mA(1C), 4.2V, 1.2mA cutoff; Discharge: CC, 43mA(1C), 3.0V cutoff; Discharge capacity should be no less than 80% of initial capacity. 43mA(1C)充电至 4.2V, 1.2mA 截止, 43mA(1C) 放电至 3.0V 截止; 放电容量不少于初始容量的 80%。 | ≥ 400 |

| | | | |
|---|----------------------|---|------------------------------------|
| 7 | Shelf Life 荷电保持能力 | Standard charge and then storage at $23 \pm 2^\circ\text{C}$ for 28 days, standard discharge. 标准充电后, 电池在 $23 \pm 2^\circ\text{C}$ 环境下储存 28 天, 然后标准放电。 | $\geq 36.5\text{mAh}(85\%C_{ini})$ |
| | | Then standard charge and standard discharge. 测试完保持容量后, 标准充电, 然后标准放电。 | $\geq 38.7\text{mAh}(90\%C_{ini})$ |
| | | Standard charge and then storage at $60 \pm 2^\circ\text{C}$ for 7 days, standard discharge. 标准充电后, 电池在 $60 \pm 2^\circ\text{C}$ 环境下储存 7 天, 然后标准放电。 | $\geq 34.4\text{mAh}(80\%C_{ini})$ |
| | | Then standard charge and standard discharge. 测试完保持容量后, 标准充电, 然后标准放电。 | $\geq 38.7\text{mAh}(90\%C_{ini})$ |

4.3 Environmental Test 环境测试

| No. 序号 | Item 项目 | Test Condition 测试方法 | Criterion 标准 |
|--------|----------------------|---|--|
| 1 | Vibration Test 振动 | <p>After standard charge, cells are to be tested as following conditions:</p> <p>Amplitude:0.8mm, Frequency: 10~55Hz(sweep: 1Hz/min), Direction: X/Y/Z axis for 90~100min. The battery is to be tested in three mutually perpendicular to each axis.</p> <p>电池充电后, 按下列条件进行试验: 振幅: 0.8mm; 频率: 10~55Hz(扫描速度: 1Hz/min); 方向: X/Y/Z 轴振动 90~100min. 电池在 X、Y、Z 三个垂直方向进行实验。</p> | <p>No leakage, no explosion, no fire, no smoke.</p> <p>不漏液、不爆炸、不起火、不冒烟</p> |
| 2 | Drop Test 跌落 | <p>Drop cells in the shipment condition (50% charge) from 1.2m height onto 5cm or thicker concrete with p-tile on it 3 times each of X, Y, and Z directions at $23 \pm 2^\circ\text{C}$.</p> <p>将电池在运输条件(50%充电)下从 1.2m 的高度自由跌落到 5cm 或更厚的水泥地面上, 从 X,Y,Z 三个方向上每个方向跌落一次, 环境温度 $23 \pm 2^\circ\text{C}$。</p> | <p>No leakage, no explosion, no fire, no smoke.</p> <p>不漏液、不爆炸、不起火、不冒烟</p> |

4.4 Safety Performance 安全性能

| No. 序号 | Item 项目 | Test Condition 测试方法 | Criterion 标准 |
|--------|-------------------------------------|--|---|
| 1 | Overcharge Test 过充测试 | After standard discharge, cells are charged at constant current of 129mA and constant voltage of 4.5V while tapering the charge current. Charging is continued for 48 hours. 电池放电后, 以恒流 129mA 充电至 4.5V 后恒压充电, 充电过程持续 48 小时。 | No explosion, no fire, no smoke. 不爆炸、不起火、不冒烟 |
| 2 | Heating Test 热冲击 | Cells are to be heated in a gravity convection or circulating air oven. The temperature of the oven is to be raised at a rate of $5 \pm 2^{\circ}\text{C}/\text{min}$ to a temperature of $130 \pm 2^{\circ}\text{C}$ at which temperature the oven is to remain for 30 minutes before the test is discontinued. 电池放置于热箱中, 温度以 $5 \pm 2^{\circ}\text{C}/\text{min}$ 的速率升至 130°C 并保温 30min。 | No explosion, no fire, no smoke. 不爆炸、不起火、不冒烟 |
| 3 | External Short-Circuit Test 外部短路 | After standard charge, cells are to be short-circuited by connecting the positive and negative terminals of cells with copper wire having a maximum resistance load of 0.1Ω . 电池充电后, 以铜线将正负极短路 (铜线内阻小于 0.1Ω)。 | No explosion, no fire, no smoke. 不爆炸、不起火、不冒烟 |
| 4 | Impact Test 重物冲击 | After standard charge, cells are impacted with their longitudinal axis parallel to the flat surface and perpendicular to the longitudinal axis of the 15.8mm diameter bar. 电池充电后, 以 15.8mm 直径的横木撞击, 电池纵轴平行于撞击平面, 垂直于横木的纵轴。 | No explosion, no fire, no smoke. 不爆炸、不起火、不冒烟 |
| 5 | Crush Test 挤压 | After standard charge, cells are crushed with their longitudinal axis parallel to the flat surface of the crushing apparatus. 电池充电后, 将其纵轴平行于冲击装置 (Per UL1642) 的平面进行挤压。 | No explosion, no fire, no smoke. 不爆炸、不起火、不冒烟 |

5 Battery Performance

5.1 Battery Technical Information

| Item 项目 | Rating 额定参数 | Note 备注 |
|--|----------------------------------|--|
| 5.1 Typical Capacity 典型容量 | 43 mAh | 8.6mA(0.2C)discharge, 3.0V cutoff 8.6mA(0.2C)恒流放电至 3.0V |
| Minimum Capacity 最小容量 | 40 mAh | |
| 5.2 Nominal Voltage 标称电压 | 3.7 V | |
| 5.3 Standard Charge Current 标准充电电流 | 8.6 mA(0.2C) | Ambient temperature 环境温度: 0 ~ +40°C |
| 5.4 Maximum Charge Current 最大充电电流 | 43 mA(1.0C) | Ambient temperature 环境温度: 0 ~ +40°C |
| 5.5 Charging Voltage 充电截止电压 | 4.20±0.03 V | |
| 5.6 Charging time (Std. charge current) 标准充电时间 (标准充电电流) | 6.0~7.0 hours | |
| 5.7 Charging time (Max. charge current) 标准充电时间 (最大充电电流) | 2.0~3.0 hours | |
| 5.8 Standard Discharge Current 标准放电电流 | 8.6 mA(0.2C) | Ambient temperature 环境温度: 0 ~ +40°C |
| 5.9 Maximum Discharge Current 最大放电电流 | 86 mA(2.0C) | Ambient temperature 环境温度: 0 ~ +40°C |
| 5.10 Discharge Cut-off Voltage 放电截止电压 | 3.0 V | |
| 5.11 Cell Impedance 电芯内阻 | ≤350 mΩ | AC Impedance 交流内阻(1KHz) |
| 5.12 Cell Weight 电芯重量 | Approx. 1.2 g | |
| 5.13 Voltage as of shipment 运输电压 | 3.7~3.9 V | |
| 5.14 Operating Temperature 工作温度 | 0~45°C -20~60°C | Charge 充电 Discharge 放电 |
| 5.15 Storage Temperature 贮存温度 | -20~60°C -20~40°C -20~20°C | 1 month 1 个月 3 month 3 个月 1 year 1 年 |

5.2 Battery Dimensions

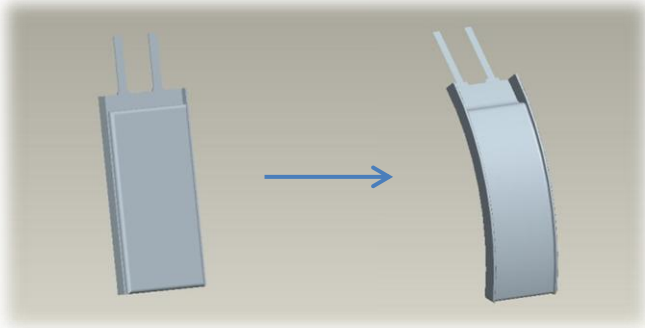

Before bent 弯折前

After bent 弯折后

Before bent 弯折前:

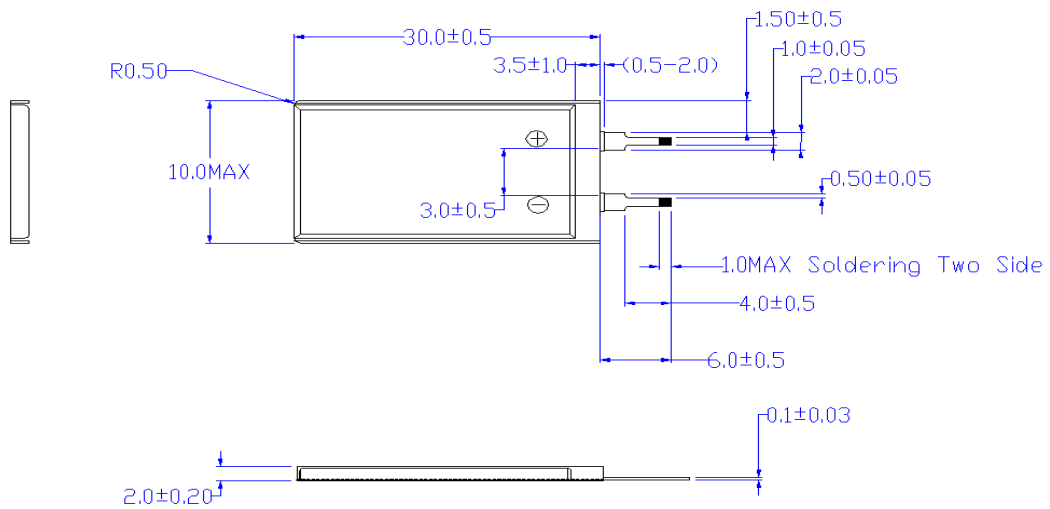

After bent 弯折后:

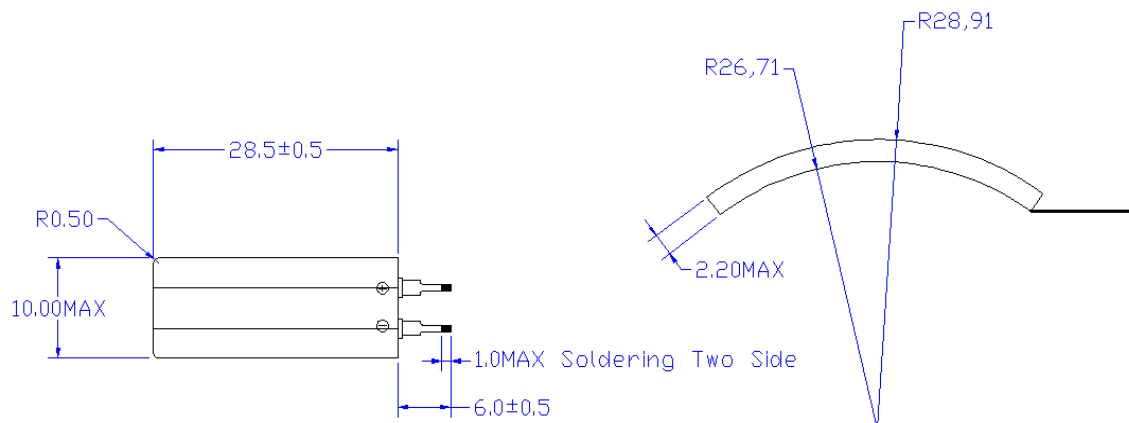

Stick glue and 3M tape 贴高温胶纸和 3M 胶带:

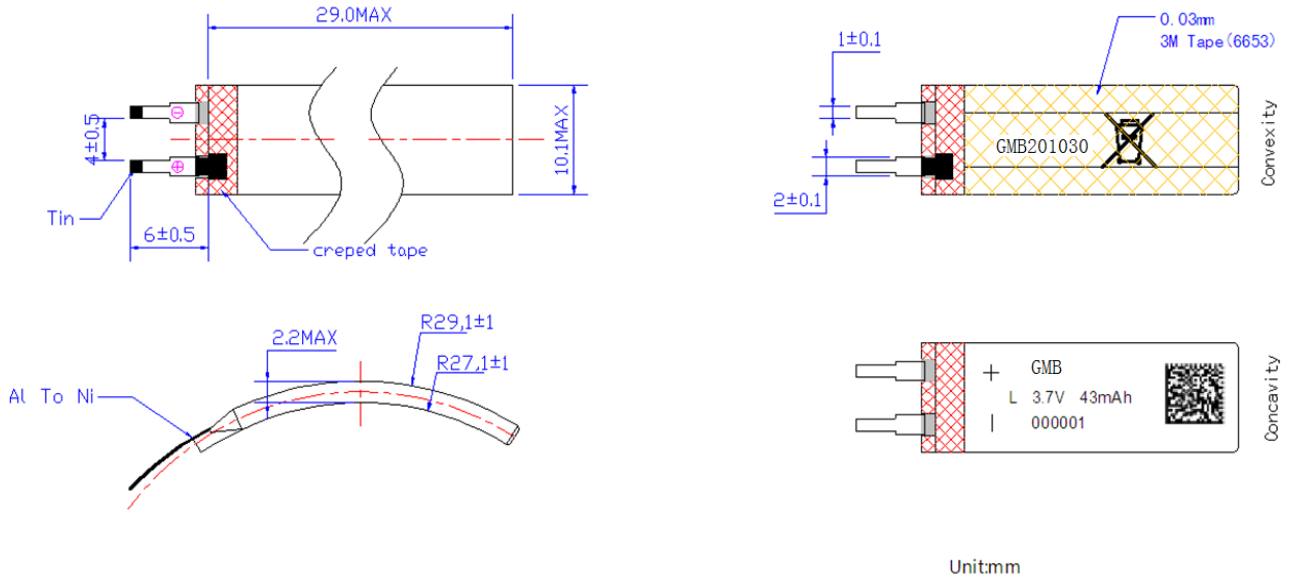

5.3 Charge & Discharge Characteristics 充放电性能

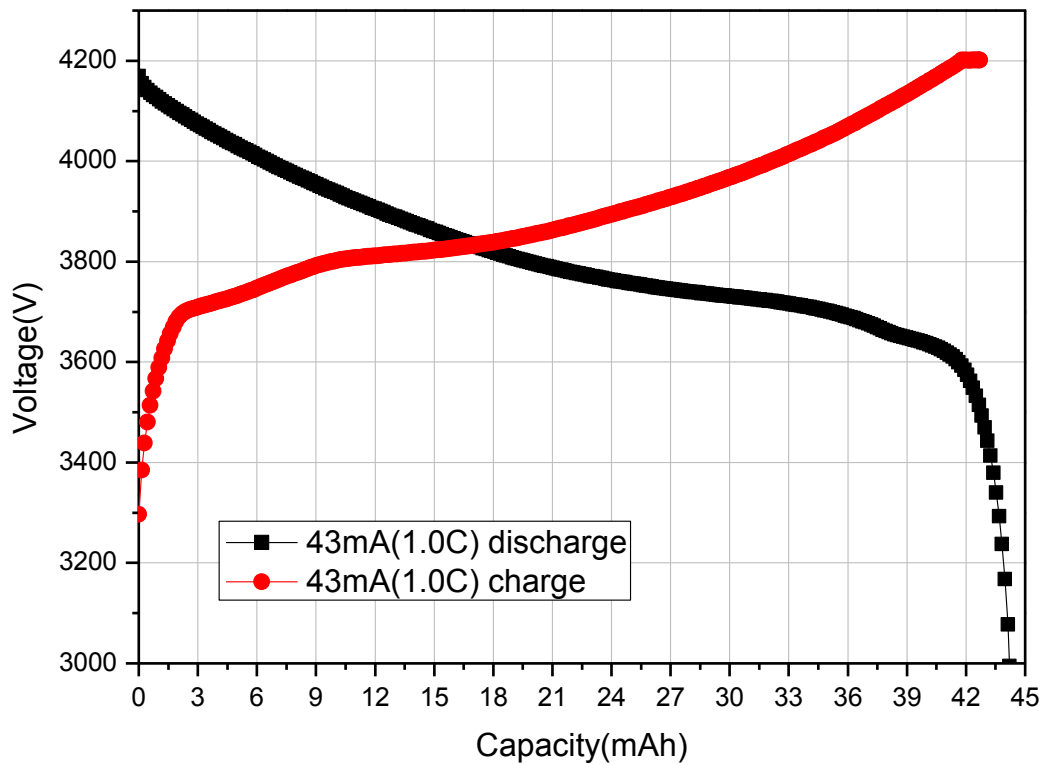

5.4 Cycle performance 循环性能

Charge: CC-CV, 43mA(1C), 4.2V, 0.03C cutoff; 43mA(1C)恒流恒压充电至 4.2V, 0.03C 截止;

Discharge: CC, 43mA(1C), 3.0V cutoff. 43mA(1C)恒流放电至 3.0V 截止;

Cycle number: 400. 循环次数 400 周;

Temperature: 20°C~25°C

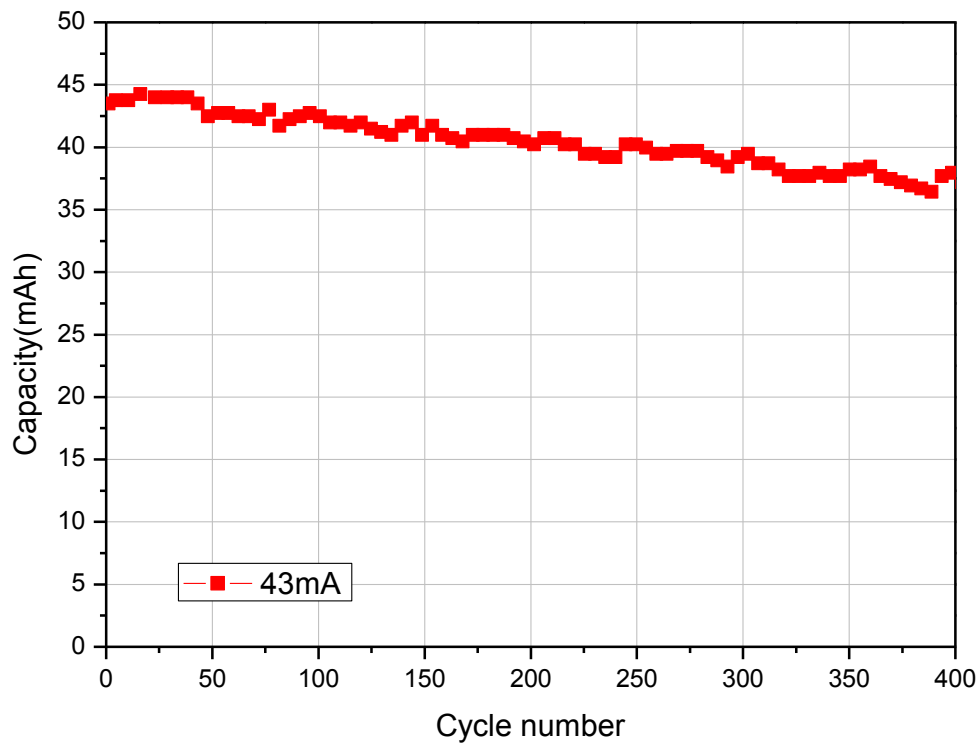

6 Print Code 喷码

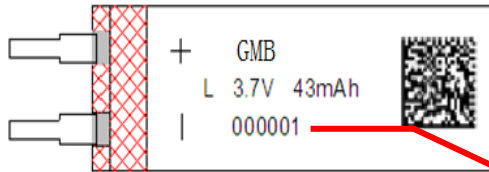

Concavity 电芯凹面

Unique Cell SN from digit8~13 of 2D code
电芯流水号，与二维码中的 8~13 位一致

2D code rule 二维码规则 :

Format of 2D code number is B22ADM3XXXXXXXXVXXXXRXXXCXX

| Note | Item | Definition |
|-------------|--------|--|
| Digit 1 | B | Component type, B=Battery |
| Digit 2 | 2 | Manufacturer's Identifier, 4=Xi'an SAFTY Battery Co. |
| Digit 3 | 2 | Build year, 1means year 2011, 2 means year 2012... (年) |
| Digit 4 | A | Build month, from 1~9, A=10, B=11, C=12 (月) |
| Digit 5 | D | Build day, 1code each use 1~9, A~Z (no I, O, Q, U) (日) |
| Digit 6 | L | Size: L, M, S (电芯尺寸: 大、中、小) |
| Digit 7 | 3 | Version 1=01, 2=02, 3=03..... |
| Digit 8~13 | XXXXXX | Unique battery SN 8-13 (电芯流水码) |
| Digit 14 | V | Voltage (电压) |
| Digit 15~18 | XXXX | Voltage data(mV) (电压值) |
| Digit 19 | R | Resistance (内阻) |
| Digit 20~22 | XXX | Resistance data(mΩ) (内阻值) |
| Digit 23 | C | Capacity (容量) |
| Digit 24~25 | XX | Capacity data(mAh) (容量值) |



Model 型号

Page

15 / 20

GMB201030R-L 43mAh 3.7V

Ver.

1.0

7 Storage 贮存

7.1 Ambient temperature 环境温度: $20^{\circ}\text{C} \pm 5^{\circ}\text{C}$

Relative Humidity 相对湿度: $65 \pm 20\%$

7.2 Please activate the battery once every 3 months according to the following method:
Charge at 0.2C(8.6mA) to 4.2V, rest 10 min, then discharge with 0.2C(8.6mA) to 3.0V/cell, rest 10 min, then charge at 0.2C(8.6mA) to 3.9V。

请每隔3个月按下面方法激活电池一次: 0.2C(8.6mA) 充电至4.2V, 休息10分钟, 然后用0.2C(8.6mA) 放电至3.0V, 休息10分钟, 0.2C(8.6mA) 充电3.9V。

8 Period of Warranty 保质期

The period of warranty is 6 months from the date of shipment. GMB guarantees to give a replacement in case of cells with defects proven due to manufacturing process instead of the customer's abuse and misuse.

电池保质期为出厂后6个月。GMB 承诺如果在保质期内由于电池本身的质量问题, 本公司将负责进行调换, 如果是由于用户误用或进行破坏性测试而产生的问题, 恕不负责。

9 Shipment 运输

Cells shall be shipped in 50% state of charge. 电池在充电50%的状态下进行运输。

10 Others 其他

Any matters that this specification doesn't cover should be conferred between the customer and GMB.

其它产品规格书未涉及到的内容可由客户与GMB共同商议。

| | | | |
|---|-------------------------|------|---------|
|  | Model 型号 | Page | 16 / 20 |
| | GMB201030R-L 43mAh 3.7V | Ver. | 1.0 |

Appendix 附录

Handling Precautions and Guideline

For LIP (Lithium-Ion Polymer) Rechargeable Batteries

聚合物锂离子充电电池操作指示及注意事项

Preface 前言

This document of 'Handling Precautions and Guideline LIP Rechargeable Batteries' shall be applied to the battery cells manufactured by Guangzhou Markyn Battery Co., Ltd .

“聚合物锂离子充电电芯操作指示及注意事项”仅适用于广州基安彼电池有限公司生产的电芯。

Note (1) : 声明一

The customer is requested to contact GMB in advance, if and when the customer needs other applications or operating conditions than those described in this document. Additional experimentation may be required to verify performance and safety under such conditions.

客户若需要将电芯用于超出本规格书规定以外的设备，或在本规格书规定以外的使用条件下使用电芯，应事先联系广州基安彼电池有限公司，因为需要进行特定的实验测试以核实电芯在该使用条件下的性能及安全性。

Note (2) : 声明二

GMB will take no responsibility for any accident when the cell is used under other conditions than those described in this Document.

对于在超出本规格书规定以外的条件下使用电芯而造成的任何意外事故，广州基安彼电池有限公司概不负责。

Note (3): 声明三

GMB will inform, in a written form, the customer of improvement(s) regarding proper use and handling of the cell, if it is deemed necessary.

如有必要，广州基安彼电池会以书面形式告知客户有关正确操作使用电芯的改进措施。

1. Charging 充电

1.1 Charging current 充电电流

Charging current should be less than maximum charge current specified in the Product Specification. Charging with higher current than recommended value may cause

damage to cell electrical, mechanical, and safety performance and could lead to heat generation or leakage.

充电电流不得超过本规格书中规定的最大充电电流。使用高于推荐值电流充电将可能引起电芯的充放电性能、机械性能和安全性能的问题，并可能会导致发热或泄漏。

1.2 Charging voltage 充电电压

Charging shall be done by voltage less than that specified in the Product Specification (4.2V/cell). Charging beyond 4.30V, which is the absolute maximum voltage, must be strictly prohibited. The charger shall be designed to comply with this condition.

充电电压不得超过本规格书规定的额定电压（4.2V/电芯）。4.30V为充电电压最高极限，充电器的设计应满足此条件。

It is very dangerous that charging with higher voltage than maximum voltage may cause damage to the cell electrical, mechanical safety performance and could lead to heat generation or leakage.

电池电压高于额定电压值时，将可能引起电芯的充放电性能、机械性能和安全性能的问题，可能会导致发热或泄漏。

1.3 Charging temperature 充电温度

The cell shall be charged within range in the Product Specification.

电池必须在本规格书规定的环境温度范围内进行充电。

1.4 Prohibition of reverse charging 禁止反向充电

Reverse charging is prohibited. The cell shall be connected correctly. The polarity has to be confirmed before wiring. In case of the cell is connected improperly, the cell cannot be charged. Simultaneously, the reverse charging may cause damaging to the cell which may lead to degradation of cell performance and damage the cell safety, and could cause heat generation or leakage.

正确连接电池的正负极，严禁反向充电。若电池正负极接反，将无法对电芯进行充电。同时，反向充电会降低电芯的充放电性能、安全性，并会导致发热、泄漏。

2. Discharging 放电

2.1 Discharging current 放电电流

The cell shall be discharged at less than the maximum discharge current specified in the Product Specification. High discharging current may reduce the discharging capacity significantly or cause over-heat.

放电电流不得超过本规格书规定的最大放电电流，大电流放电会导致电芯容量剧减并导致过热。

2.2 Discharging temperature 放电温度

The cell shall be discharged within range specified in the Product Specification.

| | | | |
|---|-------------------------|------|---------|
|  | Model 型号 | Page | 18 / 20 |
| | GMB201030R-L 43mAh 3.7V | Ver. | 1.0 |

电池必须在本规格书规定的环境温度范围内进行放电。

2.3 Over-discharging 过放电

It should be noted that the cell would be at an over-discharged state by its self-discharge characteristics in case the cell is not used for long time. In order to prevent over-discharging, the cell shall be charged periodically to maintain between 3.7V and 3.9V.

需要注意的是,在电池长期未使用期间,它可能会用其自放电特性而处于某种过放电状态。为防止过放电的发生,电池应定期充电,将其电压维持在 3.7V 至 3.9V 之间。过放电会导致电芯性能、电池功能的丧失。

The charger shall be equipped with a device to prevent further discharging exceeding a cut-off voltage specified in the Product Specification. Also the charger shall be equipped with a device to control the recharging.

充电器应有装置来防止电池放电至低于本规格书规定的截止电压。此外,充电器还应有装置以防止重复充电。

3. Protection Circuit Module 保护电路模块

The cell/battery pack shall be with a PCM that can protect cell/battery pack properly. PCM shall have functions of (1) overcharging prevention, (2) over-discharging prevention, (3) over current prevention to maintain safety and Prevent significant deterioration of cell performance. The over current can occur by external short circuit.

电芯/电池包装应配有 PCM 以正确保护电芯/电池。PCM 应具有以下功能以保证安全并防止损坏电池性能: (1) 过充保护功能; (2) 过放保护功能; (3) 过流保护

3.1 overcharging prohibition: 过充保护电压

Overcharging prohibition function shall stop charging if any one of the cells of the battery pack reaches $4.275 \pm 0.02V$.

当电池中任一电芯的电压达到 $4.275 \pm 0.02V$ 时,过充电保护功能应立即启动并停止充电。

3.2 over-discharging prohibition: 过放电保护

Over-discharging prevention function shall work to avoid further drop in cell voltage of $3.0 \pm 0.035V$ or less per cell in any cell of the battery pack. It is recommended that the dissipation current of PCM Shall be minimized to 0.5uA or less with the over-discharging prevention. The protection function shall monitor each bank of the battery pack and control the current all the time.

当电池中任一电芯的电压降至 $3.0 \pm 0.035V$ 以下时,过放保护功能应起保护作用以避免电芯的深度放电。推荐 PCM 的静态电流小于 0.5uA,并具有过放保护功能。该保护功能应实时监控所有电池。

4. Storage 贮存

The cell shall be stored within range environmental condition of specification.

电芯贮存必须是在本规格书规定的环境条件范围内贮存。

5. Handling Instructions 电池的注意事项

Read and observe the following warnings and precautions to ensure correct and safe use of Li-ion batteries.

认真阅读下面的注意事项，确保正确使用聚合物锂离子电池。GMB 对违反下述注意事项而产生的任何问题不予负责。

Danger!

危 险!

- Do not immerse the battery in water or allow it to get wet.
- 勿将电池投入水中或将其弄湿!
- Do not use or store the battery near sources of heat such as a fire or heater.
- 禁止在火源或极热条件下给电池充电! 勿在热源(如火或加热器)附近使用或贮存电池! 如果电池泄漏或发出异味, 应立即将其从接近明火处移开;
- Do not use any chargers other than those recommended by GMB.
- 请使用专用充电器!
- Do not reverse the positive(+) and negative(-) terminals.
- 勿将正负极接反!
- Do not connect the battery directly to wall outlets or car cigarette-lighter sockets.
- 勿将电池直接连接到墙上插座或车载点烟式插座上!
- Do not put the battery into a fire or apply direct heat to it.
- 勿将电池投入火中或给电池加热!
- Do not short-circuit the battery by connecting wires or other metal objects to the positive(+) and negative(-) terminals.
- 禁止用导线或其它金属物体将电池正负极短路, 禁止将电池与项链、发夹或其它金属物体一起运输或贮存!
- Do not pierce the battery casing with a nail or other sharp object, break it open with a hammer, or step on it.
- 禁止用钉子或其它尖锐物体刺穿电池壳体, 禁止锤击或脚踏电池!
- Do not strike, throw or subject the battery to physical shock.
- 禁止撞击、投掷或者使电池受到机械震动!
- Do not directly solder the battery terminals.

- 禁止直接焊接电池端子！
- Do not attempt to disassemble or modify the battery in any way.
- 禁止以任何方式分解电池！
- Do not place the battery in a microwave oven or pressurized container.
- 禁止将电池置入微波炉或压力容器中！
- Do not use the battery in combination with primary batteries (such as dry-cell batteries) or batteries of different capacity, type or brand.
- 禁止与一次电池（如干电池）或不同容量、型号、品种电池组合使用！
- Do not use the battery if it gives off an odor, generates heat, becomes discolored or deformed, or appears abnormal in any way. If the battery is in use or being recharged, remove it from the device or charger immediately and discontinue use.
- 如果电池发出异味、发热、变形、变色或出现其它任何异常现象时不得使用；如果电池正在使用或充电，应立即从用电器中或充电器上取出并停止使用！

Caution!

注 意！

Do not use or store the battery where is exposed to extremely hot, such as under window of a car in direct sunlight in a hot day. Otherwise, the battery may be overheated. This can also reduce battery performance and/or shorten service life.

不要使用处于极热环境中的电池，如阳光直射或热天的车内。否则，电池会过热，可能着火（点燃），这样就会影响电池的性能、缩短电池的使用寿命。

If the battery leaks and electrolyte gets in your eyes, do not rub them. Instead, rinse them with clean running water and immediately seek medical attention. If left as is, electrolyte can cause eye injury.

如果电池漏液后电解液进入眼睛，不要擦，应用水冲洗，立即寻求医疗救助。如不及时处理，眼睛将会受到伤害。

Use the battery only under the specification of cell. Failure to do so can result in reduced performance or a shorten service life.

只能在电芯规定的条件下使用电池，否则将会降低电池的性能或缩短电池的使用寿命。